

©2015 FlyKly, Inc.





SMART PED

IN THE BOX

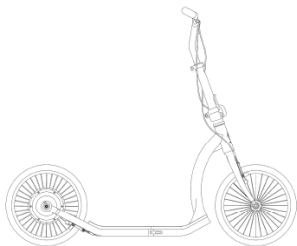

Smart Ped



Charger



Charging Cable

DOWNLOAD THE BITRIDE APP

Step 1

You can find bitride for iOS on iTunes App Store and for Android on Google Play Store.

Once you launch the app for the first time, you will need to register with a valid email address.

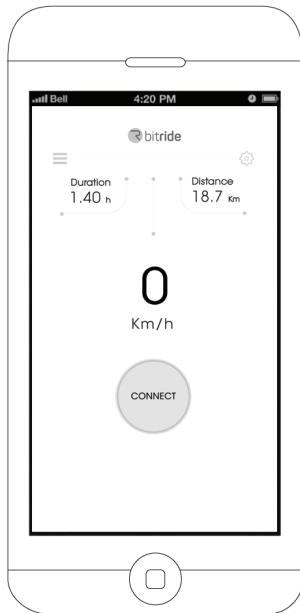

Connect the Smart Ped to BitRide App.

For iOS users:

Go to Bluetooth settings.

Connect to the Smart Ped.

Pair the Smart Ped to your iPhone.

Open BitRide App.

On the app menu, click on Ride.

Click on Connect.

For Android users:

Turn on Bluetooth.

Open BitRide App.

On the app menu, click on Ride.

Click Connect.

Select the Smart Ped that was scanned and pair the device.

NOTE: After the first connection and pairing, bitride will auto connect to your Smart Ped*

*compatible devices: Android 4.2.3 and later, iPhone 4s, 5, 5c, 5s, 6, 6 Plus, 6s (iOS 8.0 and later)

Step 2

1 Register

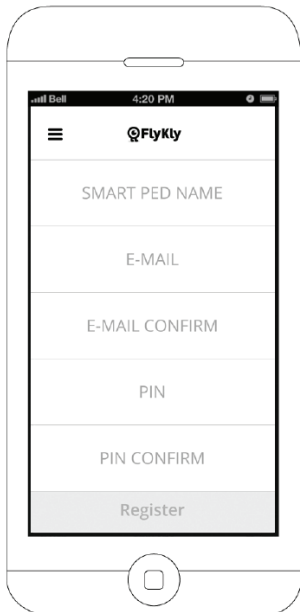

INSTRUCTIONS FOR USE

Charging

Step 1

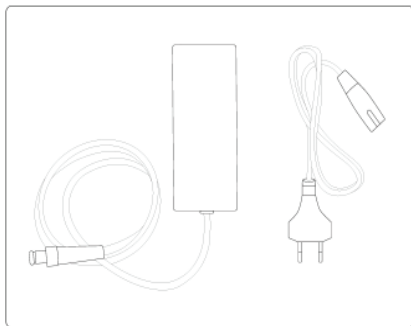

Get the charger and the cable.

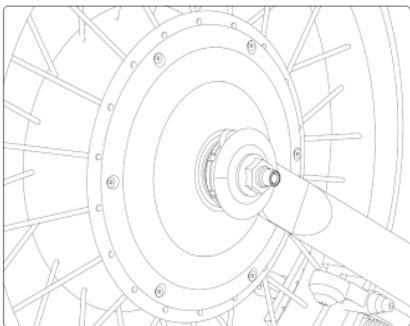

Unscrew the Rear Axle Cover.

Step 2

Connect the charger with the Smart Ped.

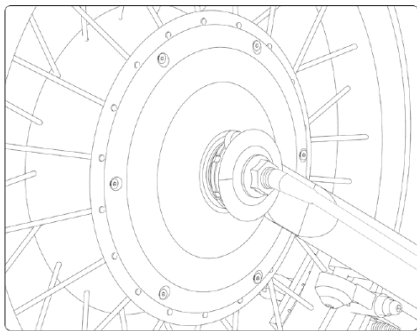

Step 3

Connect the charger to the wall socket.

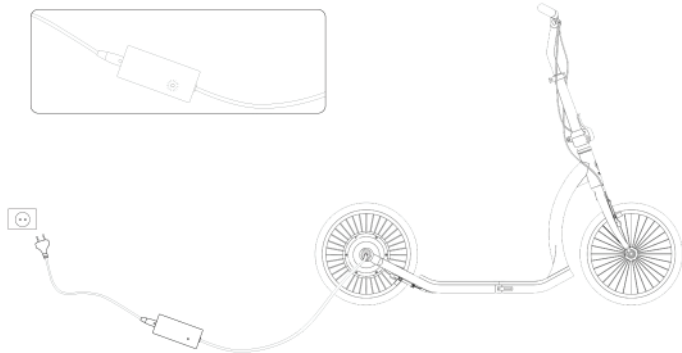

NOTE: The red light represents it is charging and the green light represents it is fully charged.

NOTE: The charger is international (100 - 240V). The cable can be replaced to work with any electrical wall socket.

Riding

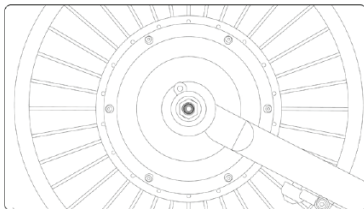

ON/OFF

The Smart Ped turns on automatically when you start kicking and you reach a certain speed (8 km/h).

After 2 min of no activity, Smart Ped will automatically turn off.

If you are connected with your smart-phone, the Smart Ped will turn off after 10 minutes of no activity.

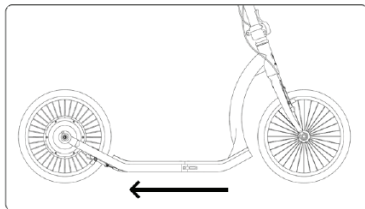

KICK ASSIST

Smart Ped recognizes your kick and it helps you in cover more distance with a single kick. The faster the speed, the higher the support.

Smart Ped NEVER increases your kick speed.

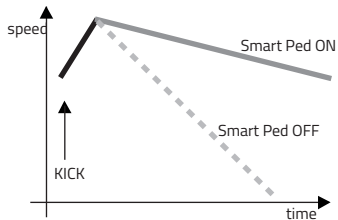

App

Ride

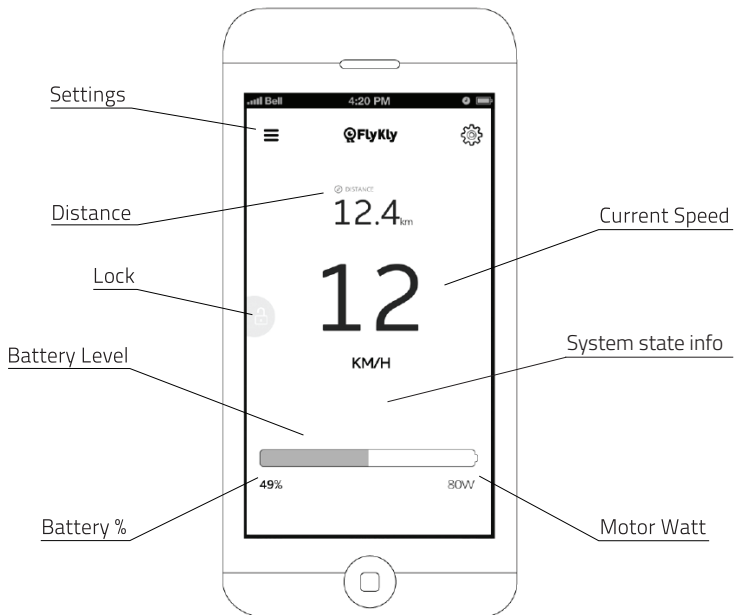

Lock



To lock the Smart Ped swipe the lock icon from left to right.



While the Smart Ped is locked, a large lock appears on the screen with estimated time the Smart Ped can stay locked.



To unlock the Smart Ped, hold the lock icon until the ring around the lock is completed.

NOTE: You can disconnect your phone, after you locked your Smart Ped.

Settings

Units:

You can set the desired units (km, miles).

Duration: set the duration, in TIME, from min to max

Distance: set the distance, in SPACE, from min to max

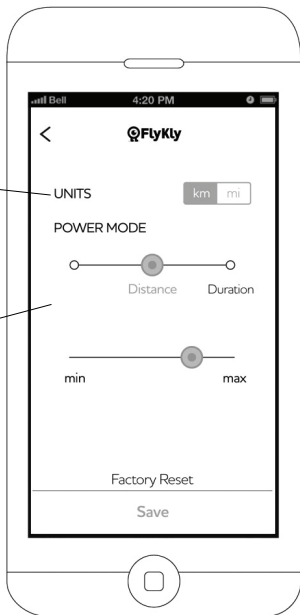

Turn off assist:

To turn the assist off, you simply set the top assisted speed and level of assistance to 0.

Off: In this position Smart Ped will not give you any assist.

Factory Reset:

If you want to change the name and the PIN code of your Smart Ped, you should perform a factory reset.

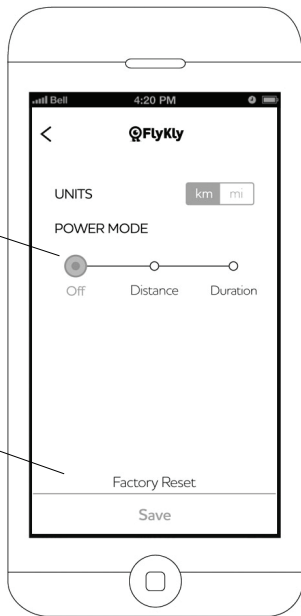

Troubleshooting

In case your Smart Ped does not work the way you think it should, please go through this Q&A.





You can not connect to the Smart Ped using BitRide app:

1. Make sure you downloaded the correct app - BitRide app (and not FlyKly app).
2. Make sure that your Smart Ped is turned on (you can see the blue light on the right side of the hub).
3. Make sure that the Bluetooth on your phone is on.
4. When you try to connect with the phone, come close to the blue light in the Smart Ped.
5. Connect to the device (name starts with SmartPed_ xxxx).
6. If it still does not connect, visit our [FAQ page](#).

Your Smart Ped does not give you any assist:

Tip: Please connect with the bitride app and check for faults. Faults will automatically show in the dashboard screen.

1. Is your Smart Ped assistance mode on? (check in the app settings)
2. Is your battery full?
3. Does the Smart Ped turn on when you charge it? (you see the blue light
4. burning)
5. Does the Smart Ped charge when you plug the charger in? (red light on charger)
6. Is everything ok with your charger - are pins and cable ok?
7. If you answered all these questions with YES and your Smart Ped still does not give you any assist, please contact us at info@flykly.com.

Icon	Description	Reason	Solution
	Electronics Fault	The BMS or/and the Motor driver do not work properly.	Smart Ped needs to be inspected. Please contact FlyKly.
	General warning	Pressing on the icon will pop up the problem.	Follow the pop up information.
	Overheating	Yellow: electric assistance is limited. Red: electric assistance is off to prevent damage to the components.	Please wait until the Smart Ped cools down.
	Internal connection fault	There is a connection problem between the electronic components inside the HUB.	Smart Ped needs to be inspected. Please contact FlyKly.
	Battery Cell Voltage Fault	Yellow: Undervoltage or Overvoltage fault. Red: Battery pack problem.	Yellow: assistance and recharge are disabled for safety reasons. Red: Smart Ped needs to be inspected. Please contact FlyKly.

WARRANTY

FlyKly Smart Ped comes with
2 year warranty (or 1000 cycles for
the battery).

For additional information go to

www.flykly.com/legal

SUPPORT

For support please go to
www.flykly.com/support

Or contact us at
info@flykly.com

THANK YOU

Thank you for your support, trust and for believing in the FlyKly project.

We could not have done it without you and we are honored you are a part of the FlyKly community.

We are proud to present your reward to you and we wish you many years of joyride.

This is just the beginning for FlyKly and we hope, together, we will continue to build a strong community and improve urban cycling around the world.

Stay Fly,

FlyKly Team